

Newsletter No. 315 – October 2020



The Atherton Aero Club is an organization of aviation enthusiasts who promote the sport of aircraft building and flying.

The organization is associated with *Recreation Aviation Australia Inc.* The Club meets at Atherton Airport every third Sunday of the month. Food and drinks are available and visitors are most welcome.



PHOTO: NQ Aero Club

Sunflower Paddock

Atherton Aero Club - Committee Contacts

President	Vice-President	Secretary	Treasurer
Simon Perkins PO Box 227 ATHERTON Q 4883 simon@spaconsulting.com.au	Dave Camp PO Box 227 ATHERTON Q 4883 admin@gorex.com.au	Tracey Hayes PO Box 227 ATHERTON Q 4883 athertonaeroclub@gmail.com	Connie Graham PO Box 227 ATHERTON Q 4883 connieg@fnoc.com.au

Web Page <http://www.athertonaeroclub.org/>

Facebook <https://www.facebook.com/AthertonAeroClub?ref=hl>

EDITOR'S NOTE - by Bill Gronbeck

Hi All,

Welcome to edition No 315. In this issue - Plenty of flying activity before the weather gets too hot. Photos and articles from various sources. Hope you enjoy the read.

A thank you to Jon, Kevin, Dave, Simon, the NQAC and others who contributed photos and articles for this edition. Please contact me with your newsletter contributions on any of the following: (07) 4036 2868 or 0408 073 142 or by email at -

williamgronbeck2@gmail.com

Watch the AAC, NQAC, Burdekin Flyers, FNQ Flyers, Donnington and Innisfail Facebook Pages for details of calendar changes and other short notice events. Check out the AAC Website for the YATN weather-cam and older AAC Newsletters.



The next **AAC Club Meeting** will be our usual get-together and **BBQ Lunch** on **Sunday the 15th of November**. Starting around **10:30am** (Allowing time for an early morning fly) at the **AAC Atherton Aerodrome** storage facility.

Visitors are most welcome.

NOTE: The CASA/AAC Safety Seminar originally scheduled for this date was held earlier in October. See report on Page 3.

Presidents Report to CASA (Continued)

Finally John examined the elephant in the room, *The Aging Pilot* and showed a smartpilot.ca video from ACE Carleton University in Canada which examined the aging pilot and found that Pilot capacity decreased over time, particularly dealing with high workload states. The study found the following greatly reduced the impacts of aging on pilot capacity:

- Obtaining higher ratings and accreditations (such as an instrument rating or instructor rating)
- Being current gave the greatest benefit and a pilot that flies a lot is the safest pilot.

Dr Martin also presented another model called the Ageing Ridge Line which considers the metaphor of walking along a mountainous ridge line and that when young the ridge line is very wide with shallow edges and so it is possible to stray somewhat and still remain safe. When we age the ridge line is much narrower and the edges are very steep, so to be safe we need to travel along the centre of the ridge, but retain the capacity to travel closer to the edges.

The next presentation will be on the 21st of February 2021 and will be by Brendan Kent, who will present on what GA and recreational pilots can learn from heavy metal pilots (Brendon up until COVID-19 flew a Boeing 787).

If you have any queries, please do not hesitate to contact me.

Regards,

Simon Perkins

Director

SPA Consulting Engineers (QLD) Pty Ltd



Attendees (Ageing Elephants) at the CASA/AAC Human Factors Seminar



Tracey Hayes | Professional Image Maker
AZURE PHOTOGRAPHY | GORGEOUS PORTRAITS

Tel: 0418 963 796

Out And About In The Far North - With Jon and Kelly 1

Great late September flight down to Hamilton Island via a stopover to Townsville to see the family. Such a beautiful place. We'll be relaxing here for a few days!



Runway 07 Townsville



Visiting Townsville Family



Departing Townsville



On The Way To Hamilton Is



The Whitsundays



Runway 14 Hamilton Island

Out And About In The Far North - With Jon and Kelly 2



At Hamilton Island



Island Golf Buggy Transport



Hamilton Island Harbour



Hamilton Island Marina



View From Our Apartment



Surreal Cloud and Sky

Out And About In The Far North - Karumba Trip with Kevin



Karumba Sunset

With a quick stop at Normanton on the way to Karumba

making local work
Far North Office Choice

fnoc.com.au
officechoice
Consider it sorted.

office choice
oic
Far North Office Choice
1 JACK STREET
11:00AM - 5:00PM
MONDAY TO FRIDAY
8.00AM TO 5PM

- Consider it Sorted for all your
- * Office Supplies
 - * Office and Outdoor Furniture
 - * Toners and Printers



07 4091 2922
far north office choice
1 Jack Street, ATHERTON QLD 4883

We deliver throughout the Far North

BUILDERS CORNER - Extracts from Jon Collins' Skybolt Blog

October 5th - Latest work...finalised the electrical system and front and rear instrument panel designs. Still awaiting my electrical components order from Steinair in the US.

Started the fibreglass work around the windscreens. Thanks to Laurie for showing me how to do this! Front screen fibreglass looks great.

Cut an inspection hole and hatch in the firewall so I can inspect/replace the fuel tank pickup tube without having to remove the engine each time. Working with 0.018" stainless steel can be tricky but it turned out very well.

Next work will be to finish the fibreglass windscreen attachments.

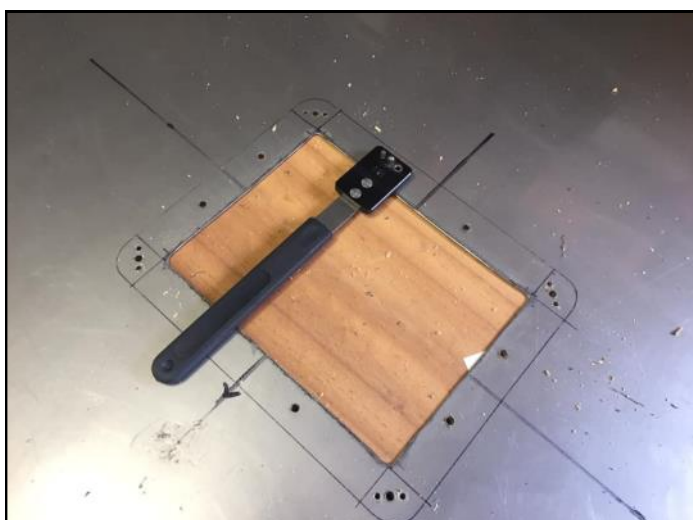
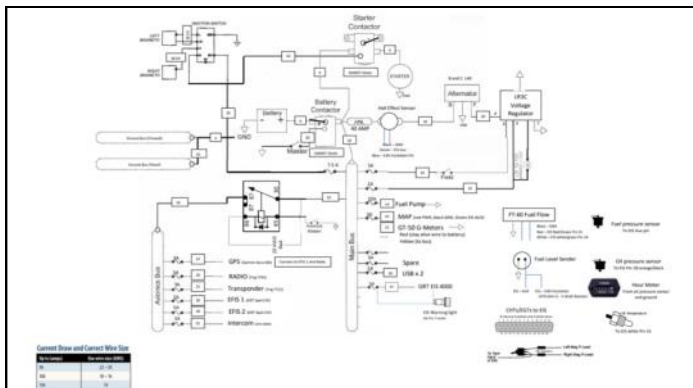
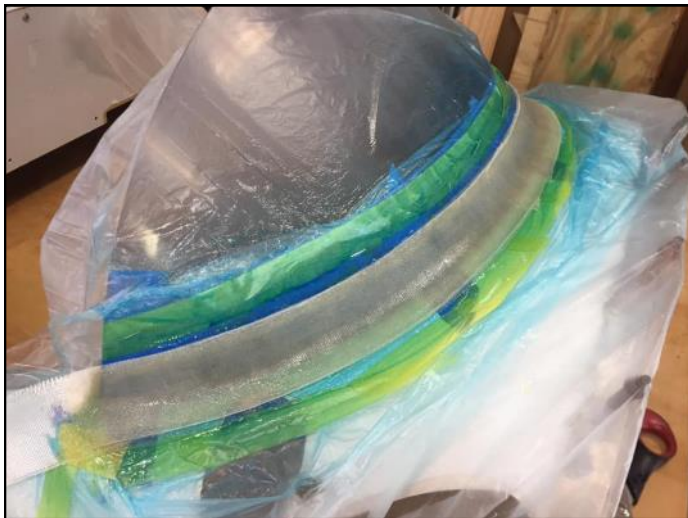
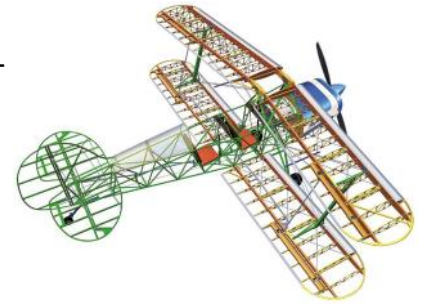

A Follow-Up to the AACs August Safety Presentation

“Radio Procedures at Uncontrolled Aerodromes”

Disagreements On The CTAF

A worthwhile recommendation from FAA (USA) Advisory Circular (AC 90-66B) on Non-Towered Airport Flight Operations is to keep disagreements and arguments off the CTAF. Some examples can include:



- Do not correct other pilots on frequency (unless it is safety critical), particularly if you are aware you are correcting a student pilot.
- If you disagree with what another pilot is doing, operate your aircraft safely, communicate as necessary, clarify their intentions and, if you feel you must discuss operations with another pilot, wait until you both are on the ground.
- Keep in mind that while you are communicating, you may block transmissions from other aircraft.
- An aircraft might be using a runway different from the one favouring the prevailing winds, e.g., for crosswind practice. The best option is to simply point out the current winds to the other pilot and indicate which runway you plan on using.

CTAF Best Practices

The Advisory Circular also includes a list of “best practices,” summarized below.

- Traffic within 10 miles of a non-towered airport should monitor and communicate, as appropriate, on the designated CTAF until leaving the area.
- Any traffic capable of radio communications should reply to your self-announcements without being prompted.
- When inbound, self-announce your position and intentions at between 10 and eight miles from the airport.
- Departing aircraft should monitor/communicate on the appropriate frequency from start-up, during taxi and until 10 miles from the airport unless required otherwise.

INNISFAIL AERO CLUB AGM

Photos from the Innisfail Aero Club Annual General Meeting on Saturday 17th October. A good attendance for the AGM and BBQ Lunch.



Out And About In The Far North

Seen at Innisfail Saturday morning 24th Oct.



Three nice home build aircraft. VH-IJP a Glasair III, VH-LEJ a Long Ez and VH-TIJ another Glasair III. Saturday morning smoko at Innisfail.



Out And About In The Far North - Cairns Flight with Dave Graham

A low run over the Cairns runway followed by a circuit of the beaches and Double Island.



Double Island & Scout Hat Island



Yorkeys Knob Marina

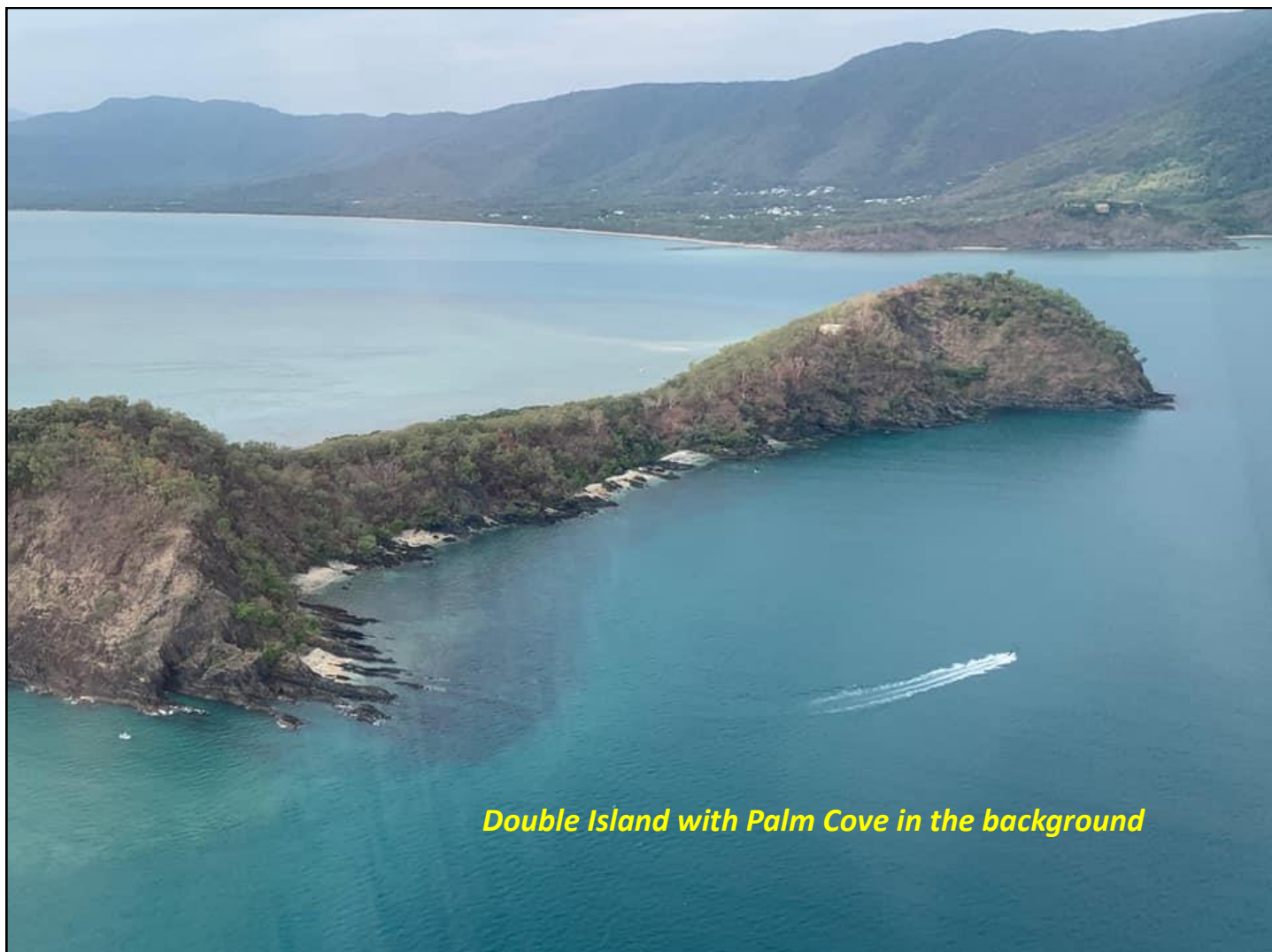

Double Island with Palm Cove in the background

Out And About In The Far North



HOT AIR BALLOON CAIRNS

Keeping it LOCAL. Come and say g'day to our local team. You may also meet some of the other Mareeba locals while you're at it. We are departing on selected days through the week so please call us or check the website for departure dates! We have smaller group departures in regulation with Covid19 safety... However, if you have a special occasion, i.e: A date for two ...and wish to fly privately, we can work with you to arrange a date that suits you to fly with just your party and the pilot.

[#holidayherethisyear](#) [#exploreathertontablelands](#) [#visitcairns](#) [#covidsafetymeasures](#)

[#tourismtropicalnorthqueensland](#)

NORTH QUEENSLAND AERO CLUB NEWS & EVENTS

SEPTEMBER 2020

UPCOMING SOCIAL EVENTS

AGM: 31ST OCTOBER, 9.00AM

CHRISTMAS PARTY: 11TH DECEMBER, 4.30PM

CLUB BOOKINGS

The club is still very busy at the moment. Particularly for instructor bookings so if you need a flight review or training make sure you book ahead to ensure you don't miss out!

IN THE AIR IN SEPT

Nathan got to head to Central QLD for some instructing in September. These are just some of the sights along the way!



ANNUAL GENERAL MEETING

It's time again for the NQAC's Annual General Meeting. All current members are encouraged to attend. The club has had a huge year, with lots of upgrades to the facilities and other changes. This is your chance to have a say in your club so join us for breakfast then take part!

2020 AGM
& Breakfast BBQ

31st of October
Breakfast from 8.30am
Meeting from 9am
North Queensland Aero Club

NORTH QUEENSLAND AERO CLUB

CHRISTMAS PARTY

2020 has been a challenging year for all of us but also a very successful year for the club with huge numbers of student achievements taking place. We could not do this without the support of our members, our board, our patron and all our wonderful students. So come along and celebrate the closing of 2020 at the NQAC Christmas Party. Please RSVP to admin@nqaeroclub.com.au so we know how many people we need to feed!

Christmas Party

11th December, 2020 • 4.30 PM - Late
North Queensland Aeroclub, Mareeba

Celebrating a challenging yet successful 2020 with food, drinks and aviation chat!

NORTH QUEENSLAND AERO CLUB NEWS & EVENTS

IT'S GETTING HOT!! SO LOOK OUT!

Dust Devils, willy willies, twisters, whirly birds whatever you want to call them they are about! Make sure you keep a good lookout and if in doubt go around!



SEPTEMBER SAFETY CHAT

How many different versions of the standard radio calls have you heard while out flying?

For most pilots both private and professional the answer is countless. So what radio calls should you actually make? What information needs to be shared? And what is an unnecessary use of the radio?

Radiotelephone Procedures can be found in both the VFRG and the AIP (GEN 3.4). Standard transmissions are designed and used to minimise misunderstandings in the air, they also help to reduce the time it takes to communicate a message. General phrases are used when possible otherwise clear, concise and plain language should be used to indicate your intentions. You can find general phrases in the AIP, most are designed to reflect a CTA environment but the AIP specifies that in Class G, pilots should use those same generic phrases unless specific Class G phrases are shown.

For those of us operating out of Mareeba we could be in Class G, C and if you get high enough even E all on the same flight so it is essential we understand the basic phraseologies and requirements of using our radios.



Some of the following Standard Phrases can be found in the AIP

Departure calls for non-controlled aerodromes "DEPARTED (location) (Time in minutes) TRACKING TO (track)/ CLIMBING TO (intended level) ESTIMATING (destination) AT (time)

Arrival calls for non-controlled aerodromes " (distance) MILES FROM (aerodrome) MAINTAINING/DESCENDING TO (level) (intentions" you might also put in information about overflying the circuit, joining crosswind or what time you will be arriving.

When you start taxiing at Mareeba or Atherton "(aircraft type), (number) POB, TAXIING FOR (destination and intentions) RUNWAY (number)"

Running late? You can make a Sartime Amendment with Brisbane Centre to avoid that awkward phone call "SARTIME (details)" then wait for the controller and amend the details when directed.

Always remember, unauthorised transmissions include; Obscene and profane language, messages which are false or intended to deceive, using the call sign of another aircraft, messages that do not pertain to operational requirements and personal or private messages

STUDENT ACHIEVEMENTS



Congratulations to Jordan Barter who got his PPL in LHI on the 16th of September. Great work Jordan!



Congratulations to Maximillian Vise who achieved his PPL in LIO on the 23rd of September 2020. Very well done Max!



A HUGE congratulations to Elios Qosja who achieved a Commercial Pilot Licence in SPW on the 26th of September 2020. Amazing achievement Elios!

NORTH QUEENSLAND AERO CLUB NEWS & EVENTS

The NQAC held our annual wings night on the 3rd of October. Many thanks to AMA for hosting. Everyone had a great night. A selection of photos from the event.



NORTH QUEENSLAND AERO CLUB NEWS & EVENTS



2020 WINGS NIGHT AWARDS



NORTH QUEENSLAND AERO CLUB NEWS & EVENTS

Norship MARINE



CONTACT DETAILS

56-62 Tingira Street
Portsmith, Cairns
Australia 4870

MAIN OFFICE

Phone: 07 4035 1722
Fax: 07 4035 1613
Email: admin@norship.com.au

PAINT SHOP

Phone: 07 4035 3167
Fax: 07 4035 6218



Bill Owen

INSURANCE BROKERS

Don't just wing it...

Suite 12/92-96 Pease St Manunda Q 4870
PO Box 521N North Cairns Q 4870

P 07 4052 1000 | E broker@billowen.com.au
billowen.com.au



FNQAMs Recently Acquired DC3



Members and helpers prepare the DC3 for removal from Becks at Mareeba

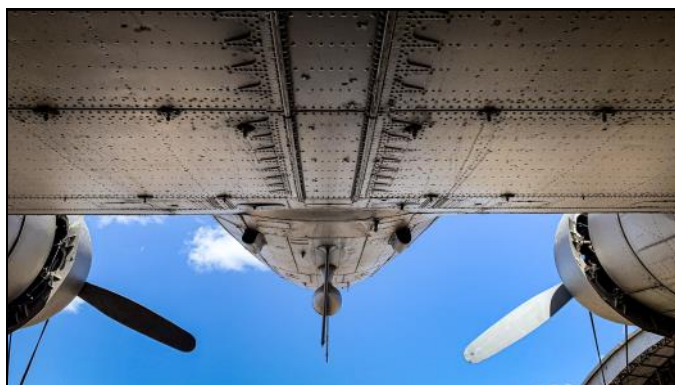

FNQ Aviation Museum

SPONSORS



For an enquiries please get in touch with:

President Steve Johnston 0409 640 209

Secretary Brendan Kent 0422 379 984

Treasurer Scott Brady 0438 751 767



Pinnarendi Station

Stay & Café

<https://www.facebook.com/Pinnarendi/>

Ron Atkinson 0419 201 622



Thank you all so much for your custom this year! Pinnarendi cafe is now closed until about Easter. The strip will still be serviceable but please call Ronnie before landing!





AIRCRAFT FOR SALE

Morgan Cheetah

Contact owner Graham Snell 0412 981 940 or 4788 8023

Currently hangared at Donnington Airpark (YDOP)

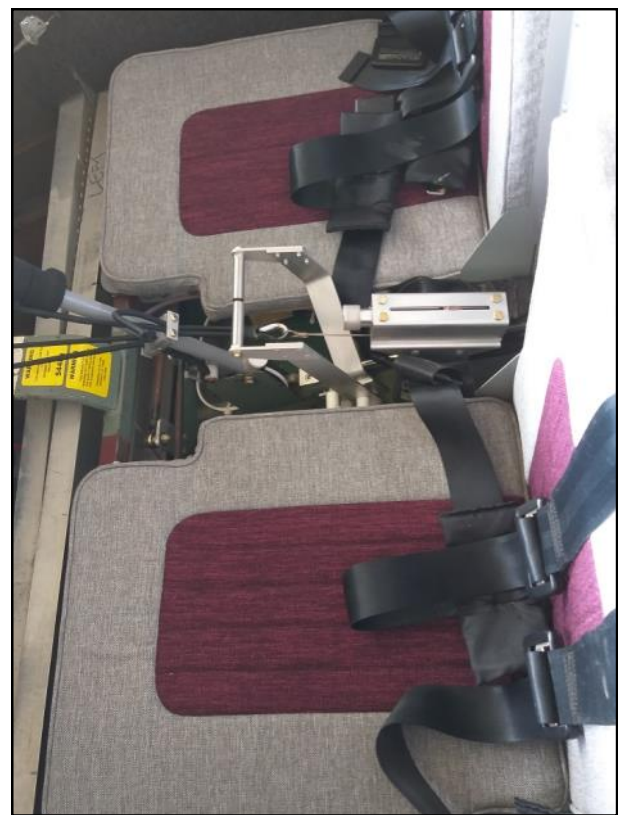
Ongoing hangarage available if required.





HO! HO! HO!

You're invited to the
Atherton Aeroclub
Christmas Party!
Date: 5th December
Time: 6.00

At the Atherton
International Club
\$45pp full xmas buffett

RSVP by 1st December
athertonaeroclub@gmail.com

Full payment to
BSB 633000
A/c 114 331 796

AAC EVENTS CALENDAR

**EVENTS MAY BE SUBJECT TO SHORT NOTICE CANCELLATION
OR POSTPONEMENT DUE COVID19 RESTRICTIONS**

Check Your Club Website or Facebook Page For changes

Atherton Aero Club—2020/2021 EVENTS

- Nov** Sun 15th Last AAC Meeting & BBQ for the year. 1030 YATN
- Dec** Sat 5th AAC Christmas Party. Atherton International Club
- Feb** Sun 21st CASA sponsored, AAC Safety Presentation. Brendon Kent. Skills Transferrable from Heavy Metal. 1030 Atherton
- Mar** Sun 21st CASA sponsored, AAC Safety Presentation. Simon Perkins. Controlled Flight Into Terrain. 1030 Atherton
- Apr** Sun 18th Final CASA sponsored, AAC Safety Presentation. An Open Discussion - Events that we have learned from. 1030 Atherton

**** All the above events are followed by a BBQ Lunch.**

OTHER EVENTS OF INTEREST

- Dec** Sat 5th Innisfail Aero Club Christmas Party
- Dec** Frid 11th NQAC Christmas Party , Mareeba 1630



LINKS TO INTERESTING ARTICLES & VIDEOS:

https://www.atsb.gov.au/publications/investigation_reports/2019/aoir/ao-2019-018/

ATSB Report. C182 CFIT near Atherton

<https://www.youtube.com/watch?v=YFDOGwptxOg>

The Most Underrated British Plane of WW2?

<https://www.youtube.com/watch?v=hrziTee4b2c&feature=youtu.be>

DC4 Skymaster Flight Sequence - SAAF Harvard 50 Year Anniversary

<https://airfactsjournal.com/2020/09/ferrying-a-1946-auster-j2-through-australia/>

Ferrying A 1946 Auster J2 Through Australia

<https://airfactsjournal.com/2020/09/stop-calling-it-the-impossible-turn/>

Stop Calling It The Impossible Turn

<https://www.avweb.com/multimedia/best-of-the-web-landing-on-a-pitching-deck/>

Landing on a Pitching Deck

https://www.atsb.gov.au/publications/investigation_reports/2019/aoir/ao-2019-072/

ATSB Report. Angel Aircraft at Mareeba

<https://airfactsjournal.com/2020/06/the-180-degree-turn-a-life-saving-maneuver-for-all-pilots-even-test-pilots/>

The 180 Degree (Weather) Turn. A Life Saving Maneuver

https://www.youtube.com/watch?v=OT-6kQmk5fo&feature=share&fbclid=IwAR1ycQOK0_fh4rq2-163gW2iJqbjbykVfqUX-ty1H4jTq0qR4r5Mo9GWqI

Cairns Scenic Flight with Jon and Kelly

Atherton Microlights

Training - Introductory Flights - Maintenance & Inspections - BFR's



NOTICE



The **Atherton Aero Club** is now an ASIC Issuing Agent for **Aviation ID Australia**.

Those seeking the issue or renewal of an Aviation Security Identification Card (ASIC) should apply directly to **Aviation ID Australia** via the following link:

<https://aviationidaustralia.net.au/application.html>

Once the ASIC card has been approved the applicant will be advised and the required “face-to-face” identity check carried out locally by an Atherton Aero Club representative. On the satisfactory completion of the identity check the local agent will hand over the ASIC card to the applicant.

AIRCRAFT FOR SALE AND WANTED

If you have, or know of, an aircraft for sale please contact me directly by telephone or email with full details. The AAC offers free advertising in the club newsletter as a service to local flyers. Direct emailing of your advert to aviators on the club mailing list is available should your advert be received after the publication cut-off date. *Bill Gronbeck, EDITOR.*



INTERESTED IN BUILDING YOUR OWN AIRCRAFT?

The Sport Aircraft Association of Australia (SAAA) is an organization that has mentored and assisted many owner builders, for both VH and Ultralight registered aircraft.

Further information on the SAAA's National and FNQ Chapter 34 websites:

<http://www.saaa.com/>

<http://www.saaafnq.com/>

Local contact is:

Laurie Wincen (Secretary) laurie19@gmail.com

ATHERTON AERO CLUB CORPORATE SPONSORS

Norship MARINE



CONTACT DETAILS

56-62 Tingira Street
Portsmith, Cairns
Australia 4870

MAIN OFFICE

Phone: 07 4035 1722
Fax: 07 4035 1613
Email: admin@norship.com.au

PAINT SHOP

Phone: 07 4035 3167
Fax: 07 4035 6218



Bill Owen INSURANCE BROKERS

Don't just wing it...

Suite 12/92-96 Pease St Manunda Q 4870
PO Box 521N North Cairns Q 4870

P 07 4052 1000 | E broker@billowen.com.au
billowen.com.au

spa consulting engineers (QLD)

Electrical & Roadway Lighting Consultants

Address: P.O. Box 604
North Cairns
Queensland
4870

E-mail: admin@speconsulting.com.au
Telephone: 07 4032 3311

Cairns Office:
Street Address: 144 Pease Street, Manora
Postal Address: P.O. Box 664, North Cairns 4870
Phone: 07 4032 3311
For all mail please only use our postal address.

Townsville Office
Street Address: Suite 8 , 286 Ross River Rd. Aitkenvale
Postal Address: PO Box 4706, Kirwan 4817
Phone: 07 4728 3026



JACX PTY LTD

PLUMBING, DRAINAGE, GASFITTING AND HOME IMPROVEMENTS

0418 774 163

xjac@bigpond.net.au

454 Varley Street
Yorkeys Knob QLD 4878



office choice™



Support your independent, locally-owned, business

Far North Office Choice

07 4091 2922
1 Jack Street, Atherton, QLD 4883
sales@fnoc.com.au

AVIATION MEDICALS

available at

The Doctor House

Dr. Diana House
D.A.M.E

Ph. 4095 2400

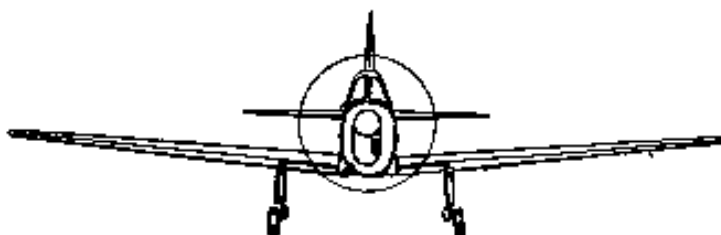

Atherton Aero Club - Membership Application / Renewal

New Member

Returning Member



PERSONAL DETAILS

Full name		Date of Birth	
Street address		State	Postcode
Postal address		State	Postcode
Email address		Occupation	
Telephone	ah	(h)	mobile

MEMBERSHIP

<input type="checkbox"/> \$ 60.00	Single Member	Single member with voting rights
<input type="checkbox"/> \$ 100.00	Family Member	Two members with voting rights
<input type="checkbox"/> \$ 50.00	Associate Member	Single member with NO voting rights
<input type="checkbox"/> no charge	Student Member	Single member with NO voting rights

PAYMENT

Forms to be sent to: <i>The Treasurer</i> Connie Graham PO Box 227 ATHERTON QLD 4883	or email to: connleg@nac.com.au
Payments can be made by: EFT, Cheque cash, or at the Bendigo Bank	
EFT Details: Atherton Aero Club BSB 633000 ACC 114331706 (Ref - Your Name)	

I hereby apply for membership to the Atherton Aero Club and agree to abide by the Constitution and any rules and regulations thereof. I further agree that my contact details may be made available to other members of the association as the Management Committee deems necessary.

Signed _____ Dated _____

Print name: _____ Print name: _____

OFFICE USE ONLY

Membership type		Receipt No		Fee Paid	\$
-----------------	--	------------	--	----------	----

THE SECOND LAST PAGE

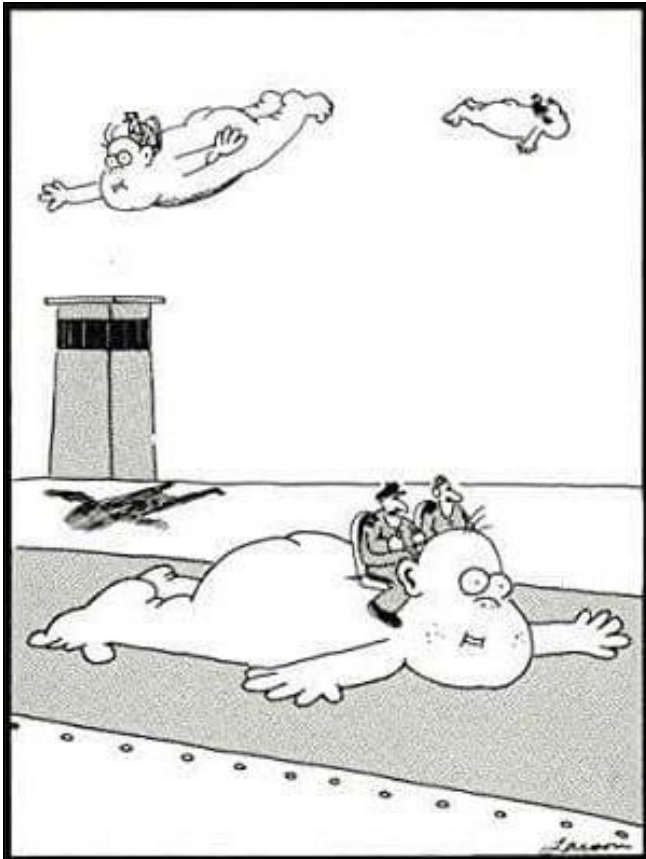

"Fuel ... check. Lights ... check. Oil pressure ... check. We've got clearance. OK, Jack — let's get this baby off the ground."



- Mom... are you gonna smoke all that by yourself?
- I'm putting away the Christmas Tree! You idiot!!

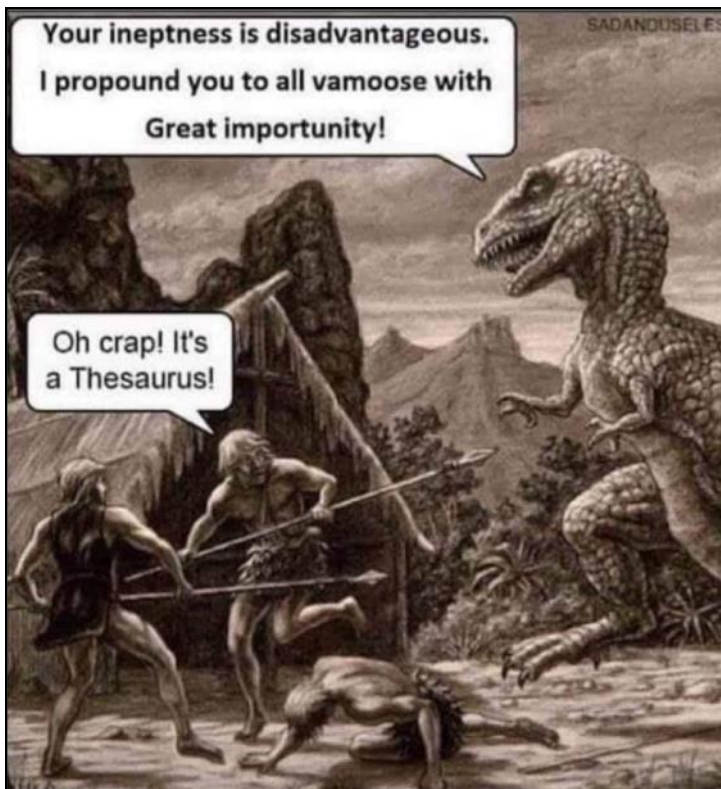

Your ineptness is disadvantageous.
I propound you to all vamoose with
Great impotunity!

Oh crap! It's
a Thesaurus!



On one hand it was a 40 million dollar plane,
on the other hand the spider was
inside the cockpit.

THE LAST PAGE

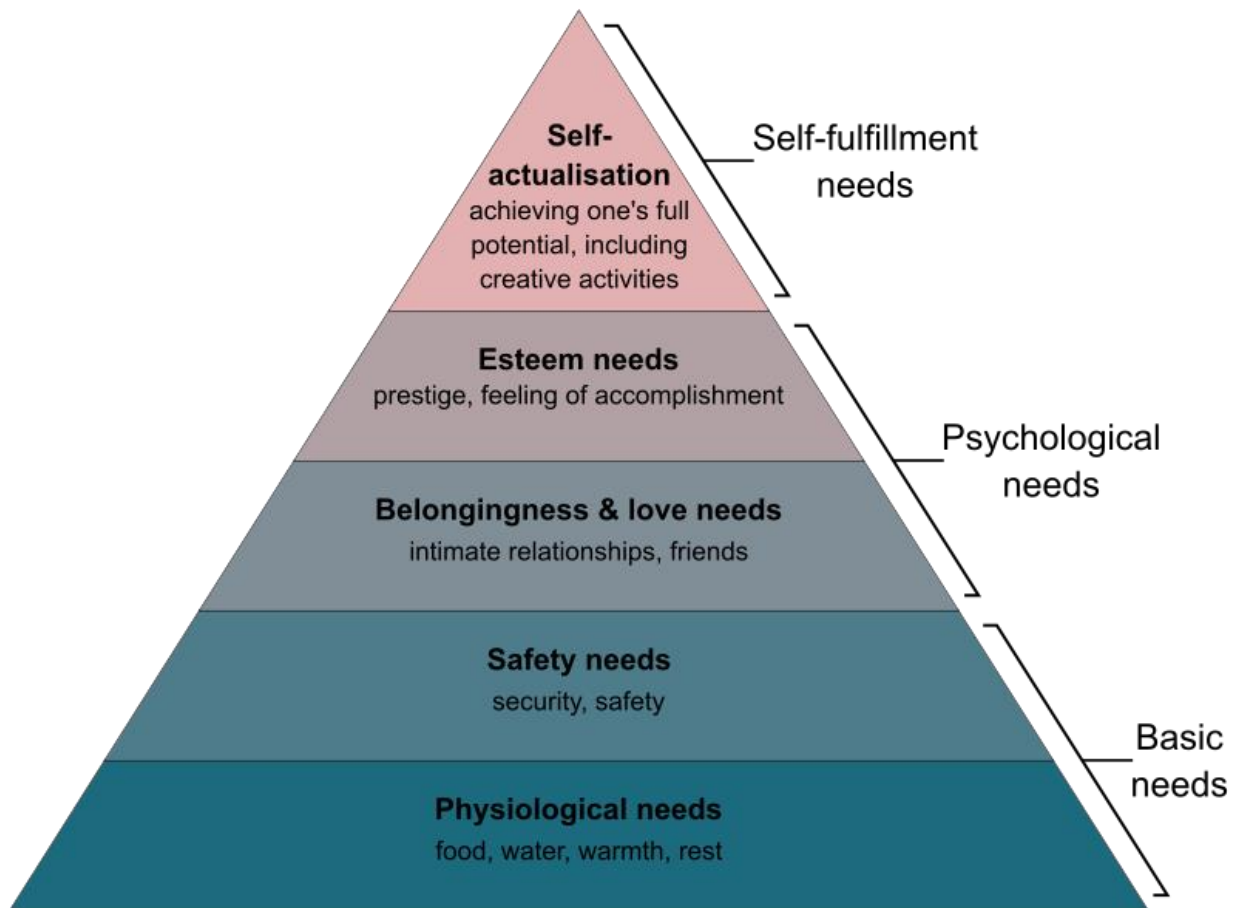

Maslow's hierarchy of needs, represented as a pyramid with the more basic needs at the bottom

